



## BAM-35 Swing Door System

The BAM-35 is a 2 1/8" medium style swing door, compatible with ES 4520 Storefront. This door is ideal for interior areas, providing an exclusive architectural design.



### System Description:

- Single or double acting operation
- Designed for 1/4" monolithic and 1" Insulated glass
- Medium style : 3 1/2" wide
- Leaf Depth: 1 3/4"
- Frame Depth: 4 1/2"
- Sight Line: 2"
- Design Load:
  - Single door: 30 psf
  - Double door: 25 psf
- Water Infiltration:
  - Single door: 4.5 psf
  - Double Door: 3.8 psf

### Features:

- Panic Device
- ADA Thresholds
- Available with butt hinges or standard offset pivots
- Bolted and welded bracket corners
- Pre-assembled door leaf
- Anodized, painted or wood grain finishes

Website: [www.BuntingArchitecturalMetals.com](http://www.BuntingArchitecturalMetals.com)

Phone: 412-820-2200



## Elevations

Double Acting

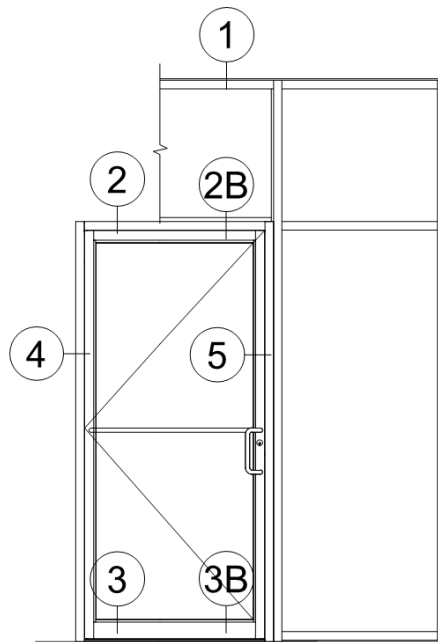

Single Acting

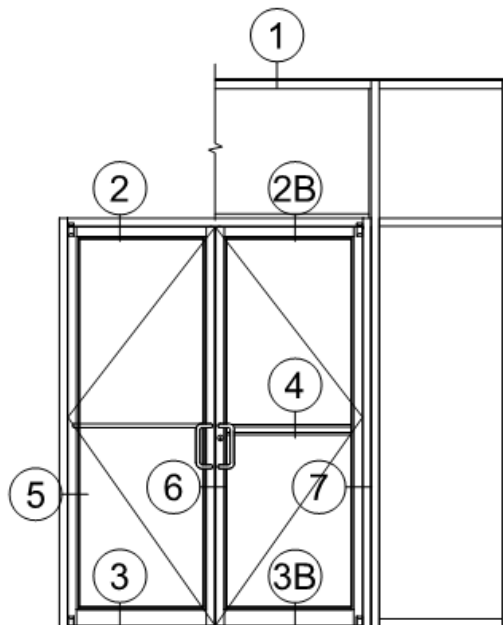

## Horizontal Sections

### Double Acting

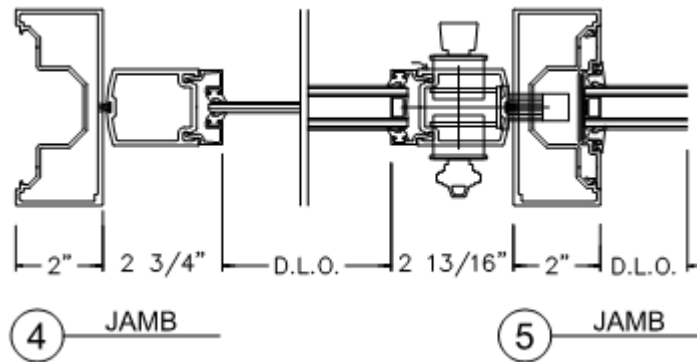

### Single Acting

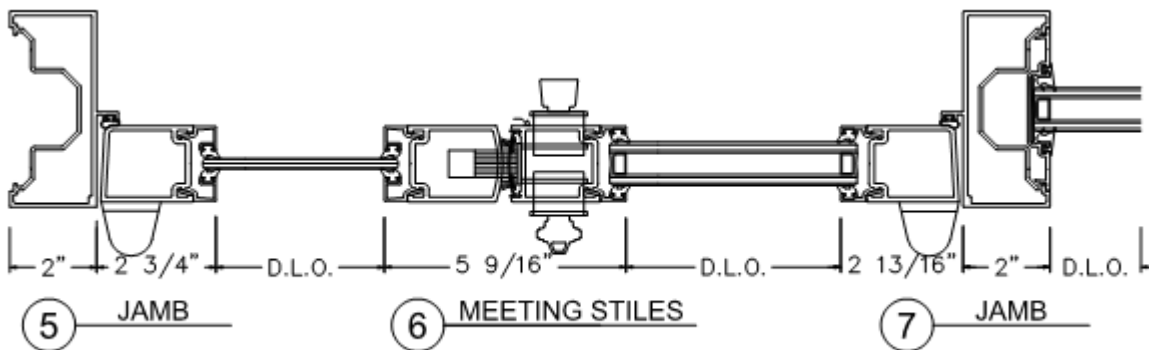

## Vertical Sections

### Double Acting

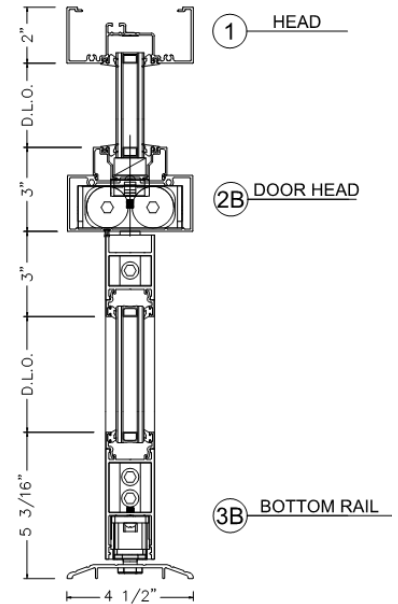
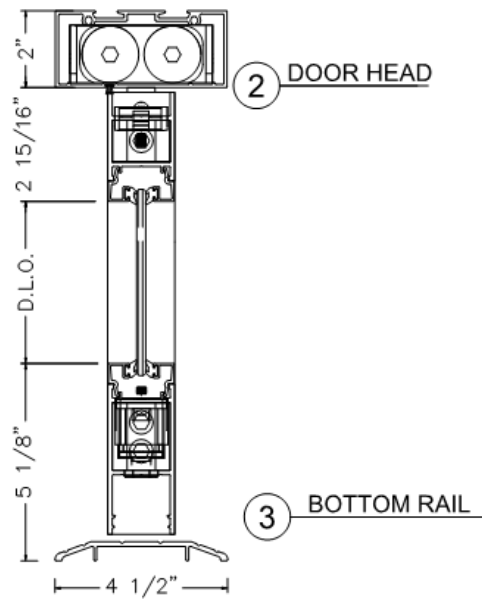

### Single Acting

