

Fabrication and Installation Instructions

X-Fastenate Panel Framing System: Series 2000

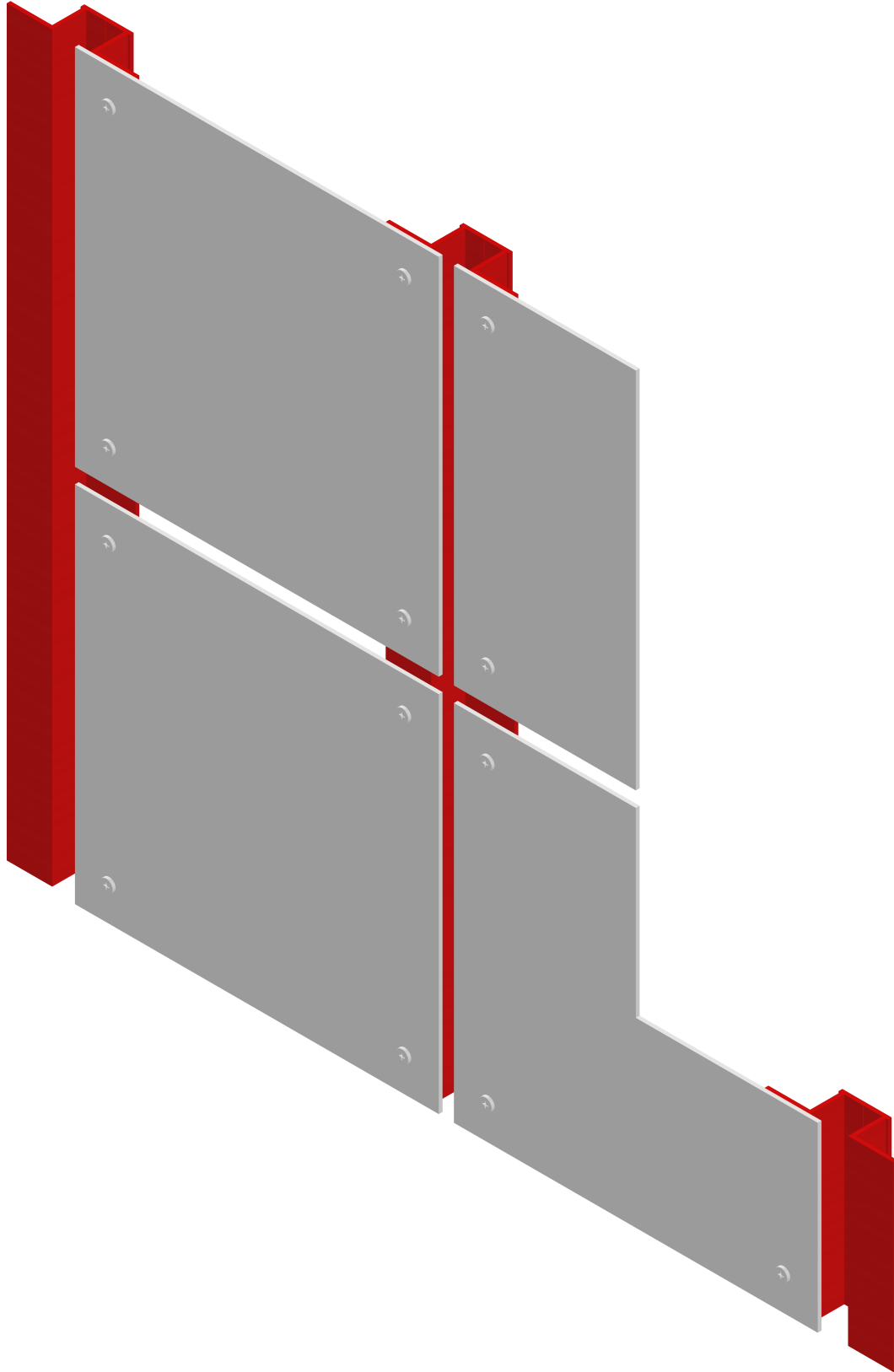

Fabrication and Installation Instructions

X-Fastenate Panel Framing System: Series 2000



Table of Contents

Cover	1
Table of Contents	2
General Notes/Handling, Storing, and Protecting Aluminum Material	3
General Rules	4
Vertical Gull and Panel Stiffener Fabrication	5
Panel Assembly	6
Installation Steps 1 - 4	7
Installation Step 4	8

Fabrication and Installation Instructions

X-Fastenate Panel Framing System: Series 2000

General Notes

THESE FABRICATION AND INSTALLATION INSTRUCTIONS ARE A SUPPLEMENT TO THE APPROVED SHOP DRAWINGS. USE THIS DOCUMENT IN CONJUNCTION WITH THOSE DRAWINGS.

DESIGN PARAMETERS

1. IN ORDER TO ENSURE STRUCTURAL PERFORMANCE, NO OTHER ATTACHMENTS TO THE PANELS OR FRAMING SHOULD BE MADE BY CONTRACTORS OTHER THAN BUNTING, WITHOUT PRIOR WRITTEN APPROVAL FROM BUNTING.

STRUCTURE BY OTHERS

1. THE BUILDING STRUCTURE AND COMPONENTS THEREOF MUST BE CAPABLE OF SAFELY CARRYING THE LOADS IMPOSED BY THE PANEL SYSTEM, INCLUDING BUT NOT LIMITED TO DEAD LOADS OF THE PANEL SYSTEM, WIND LOADS SHOWN HEREIN ON DRAWINGS AND/OR CALCULATIONS, THERMAL LOADINGS, SEISMIC LOADINGS, SNOW LOADINGS, AND LIVE LOADINGS.

2. VERIFICATION OF SUBSTRATE:

THE MAXIMUM DEVIATION IN THE PLANE OF THE SUBSTRUCTURE MUST NOT EXCEED +/- 1/4" IN ANY 20 FOOT LENGTH HORIZONTALLY OR VERTICALLY AND CANNOT VARY MORE THAN 1/2" OVER THE ENTIRE BUILDING ELEVATION. TRANSITION AREAS SUCH AS CORNERS AND SOFFITS MUST HAVE THE SUBSTRUCTURE WITHIN +/- 1/8" OF THE THEORETICAL GIRT PLANES. SUBSTRUCTURE ALIGNMENT OUTSIDE OF THE ABOVE LIMITS MUST BE CORRECTED PRIOR TO CLADDING INSTALLATION.

INSTALLATION SHALL NOT PROCEED UNTIL THE SUBSTRUCTURE IS CORRECTED. MAXIMUM SHIM UP TO 1/4" AS REQUIRED TO BRING THE GIRT PLANE TO WITHIN +/- 1/16" OF THE THEORETICAL GIRT PLANE. SHIMMING MAY REQUIRE LONGER FASTENERS.

THE SURFACE OF THE GIRT TO WHICH PANELS ARE TO BE ATTACHED MUST BE FREE OF BOLT AND RIVET HEADS, EXCESSIVE WELDS, OR ANY OTHER OBSTRUCTIONS WHICH COULD PREVENT PROPER BEARING. ALL STRUCTURAL SUPPORTS SHALL BE IN PLACE AND ALL SAG RODS, DIAGONAL BRACING, AND CONNECTIONS SHALL BE TIGHTENED BEFORE WORK PROCEEDS. WELD ALL SLOTTED CONNECTIONS INTENDED FOR ALIGNMENT PURPOSES ONLY UPON COMPLETION OF ALIGNMENT.

IN NO CASE SHALL GIRTS BE ERECTED AND ALIGNED PRIOR TO POURING THE FLOOR AND/OR ROOF SLABS. DEAD LOAD DEFLECTIONS WILL CAUSE SEVERE GIRT ALIGNMENT PROBLEMS.

3. CONCRETE MUST BE 6000 PSI OR BETTER TO MOUNT THE PANEL SYSTEM.

EVERY EFFORT IS BEING MADE TO ELIMINATE ERRORS; HOWEVER, SINCE ERRORS CAN AND WILL HAPPEN, BUNTING WILL NOT ASSUME RESPONSIBILITY BEYOND MANUFACTURING IN ACCORDANCE WITH APPROVED DRAWINGS OR RESPONSIBILITY FOR ERRORS RESULTING FROM THE USE OF THESE DRAWINGS BY OTHER TRADES.

Handling, Storing, and Protecting Aluminum Material

THE FOLLOWING PRECAUTIONS ARE RECOMMENDED TO ASSURE EARLY ACCEPTANCE OF YOUR PRODUCTS AND WORKMANSHIP.

A) HANDLE CAREFULLY - DO NOT DROP FROM THE TRUCK. STACK WITH ADEQUATE SEPARATION SO MATERIAL WILL NOT RUB TOGETHER. STORE OFF THE GROUND. PROTECT AGAINST ELEMENTS AND OTHER CONSTRUCTION TRADES.

B) KEEP MATERIAL AWAY FROM WATER, MUD, AND SPRAY - PREVENT CEMENT, PLASTER, AND OTHER MATERIALS FROM DAMAGING THE FINISH.

C) PROTECT THE MATERIALS AFTER ERECTION BY WRAPPING WITH KRAFT PAPER - OR BY ERECTING VISQUEEN/CANVAS SPLATTER SCREENS. CEMENT, PLASTER, TERRAZZO, AND OTHER ALKALINE MATERIALS ARE VERY HARMFUL TO THE FINISH AND SHOULD BE REMOVED WITH WATER AND MILD SOAP BEFORE SETTING OCCURS. UNDER NO CIRCUMSTANCES ALLOW THESE MATERIALS TO DRY OR PERMANENT STAINING WILL OCCUR. PRIOR TO THE SETTING OF OTHER MATERIALS REQUIRE THE CONTRACTOR TO CLOSELY SUPERVISE OTHER TRADES SO AS TO PREVENT MARRING OR DISCOLORATION FROM ANY CAUSE.

D) GENERAL CONTRACTOR SHALL TAKE NECESSARY MEASURE TO PROTECT ALUMINUM FROM WELDING OPERATIONS BY CONTRACTORS OTHER THAN BUNTING.

Fabrication and Installation Instructions

X-Fastenate Panel Framing System: Series 2000

General Rules

THE FOLLOWING PRACTICES ARE RECOMMENDED FOR ALL INSTALLATIONS.

A) READ COMPLETE INSTRUCTIONS BEFORE ORDERING PANELS OR FABRICATED MATERIAL.

B) CHECK SHOP DRAWINGS TO BECOME THOROUGHLY FAMILIAR WITH THE JOB.

C) ALL MATERIALS ARE TO BE INSTALLED PLUMB, LEVEL, AND TRUE.

D) ALL WORK SHOULD START FROM ESTABLISHED BENCH MARKS AND COLUMN CENTER LINES ESTABLISHED BY THE ARCHITECTURAL DRAWINGS AND THE GENERAL CONTRACTOR.

E) THE SEQUENCE OF ERECTION SHOULD BE COORDINATED WITH THE JOB SUPERINTENDENT SO DELAYS ARE PREVENTED AND RISK OF MATERIAL DAMAGE IS MINIMIZED. IF PRESETTING OF ANCHORAGE IS REQUIRED, COORDINATE WITH GENERAL CONTRACTOR AND SUPERVISE LOCATION.

F) MAKE CERTAIN CONSTRUCTION WHICH WILL RECEIVE YOUR MATERIALS IS ACCORDING TO THE CONTRACT DOCUMENTS. IF NOT, NOTIFY THE GENERAL CONTRACTOR IN WRITING AND RESOLVE DIFFERENCES BEFORE PROCEEDING WITH YOUR WORK.

G) INSULATE ALL ALUMINUM TO BE PLACED DIRECTLY IN CONTACT WITH THE MASONRY OR INCOMPATIBLE MATERIALS WITH A HEAVY COAT OF ZINC CHROMATE OR BITUMINOUS PAINT. ALL MILL FINISHED/UNFINISHED ALUMINUM MUST HAVE A SEPARATOR (NON-METALLIC) BETWEEN DISSIMILAR METALS.

H) FOLLOW BUNTING FABRICATION AND INSTALLATION INSTRUCTIONS.

I) CHECK ALL MATERIAL ON ARRIVAL FOR QUANTITY.

J) BE SURE TO HAVE ALL THE MATERIALS AND TOOLS NEEDED TO BEGIN THE INSTALLATION.

1. APPROVED SHOP DRAWINGS.
2. LEVEL AND PLUMB (TRANSIT).
3. FASTENERS AND REQUIRED DRILL BITS AND DRIVERS.
4. PERIMETERS AND ACCESSORIES SUCH AS ANCHORS, FASTENERS, AND END CAPS.
5. METAL PANELS FOLLOWING THE DESIGN SPECIFICATIONS.

Fabrication and Installation Instructions

X-Fastenate Panel Framing System: Series 2000

Vertical Gull Fabrication

REFERENCE APPROVED SHOP DRAWINGS FOR VERTICAL LENGTHS. ACTUAL PROJECT CONDITIONS WILL DETERMINE SPECIFIC GULL DESIGN AND QUANTITY.

MOUNTING BRACKET TYPES:

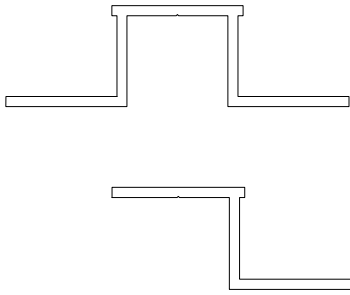

VERTICAL GULL ALUMINUM EXTRUSION X20001
USED FOR MIDDLE PANEL CONNECTIONS

HALF VERTICAL GULL ALUMINUM EXTRUSION X20002
USED FOR PERIMETER PANELS (PARAPETS, OPENING SILLS, ETC.)

VERTICAL GULL AND HALF VERTICAL GULL HAVE THE SAME FABRICATION METHOD. VERTICAL GULL IS SHOWN. FOLLOW THESE STEPS AND DIMENSIONS FOR HALF VERTICAL GULL FABRICATION.

BE SURE TO ACCOUNT FOR CORRECT NUMBER OF EACH TYPE OF VERTICAL GULL.

CUT THE VERTICAL GULL EXTRUSION TO INSTALLATION WALL HEIGHT.

AXONOMETRIC VIEW

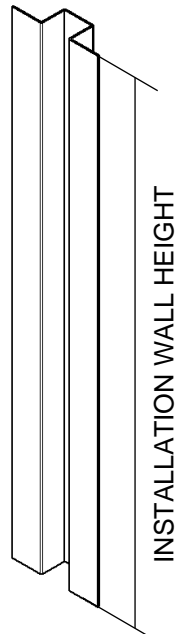

VERTICAL GULL AND HALF VERTICAL GULL LENGTH IS DEPENDENT ON PANEL AND INSTALLATION SITE DIMENSIONS.

MOUNTING HOLES MAY BE FIELD DRILLED IF DEEMED NECESSARY. REFERENCE APPROVED SHOP DRAWINGS.

Panel Stiffener Fabrication

THE FOLLOWING STEPS SHOULD ONLY BE TAKEN IF THE PANEL SIZE IS GREATER THAN 28 SQUARE FEET.

CUT THE 1 1/2" x 1" CHANNEL STIFFENER TO 8" SHORTER THAN THE PANEL WIDTH. SPACING OF STIFFENER(S) DETERMINED BY ENGINEERING CALCULATIONS.

STIFFENER WILL LAY FLAT DIRECTLY AGAINST THE ALUMINUM PANEL.



PANEL STIFFENER ALUMINUM EXTRUSION X10003

BACK VIEW

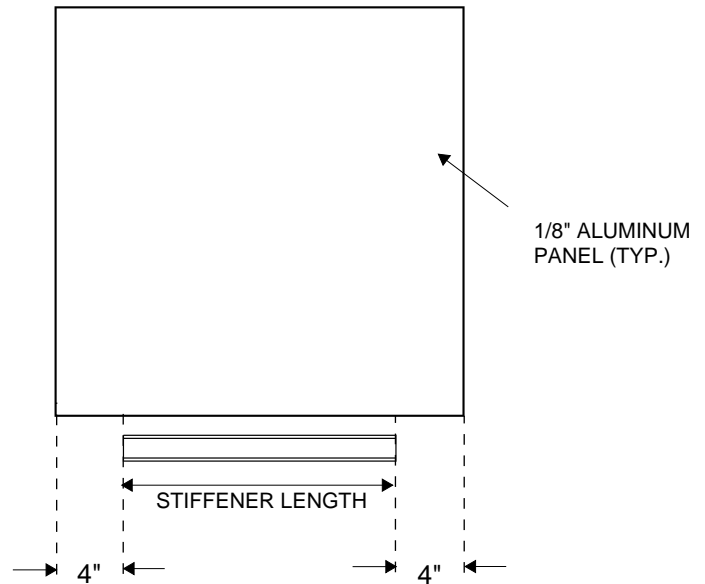

STIFFENER DIMENSIONS DEPENDENT ON PANEL DIMENSIONS. REFERENCE APPROVED SHOP DRAWINGS FOR PANEL DIMENSIONS TO DETERMINE STIFFENER LENGTH.

Fabrication and Installation Instructions

X-Fastenate Panel Framing System: Series 2000

Panel Assembly

THE FOLLOWING STEPS SHOULD ONLY BE TAKEN IF THE PANEL SIZE IS GREATER THAN 28 SQUARE FEET.

APPLY VHB TAPE TO THE BASE OF THE STIFFENER AND SECURE IT TO THE PANEL ASSEMBLY TO SUPPORT THE CENTER OF THE PANEL.

CENTER THE STIFFENER HORIZONTALLY, CREATING A 4" GAP BETWEEN THE STIFFENER AND PANEL ON BOTH ENDS TO ALLOW FOR EXPANDING AND CONTRACTING UNDER DIFFERENT WEATHER CONDITIONS.

BACK VIEW

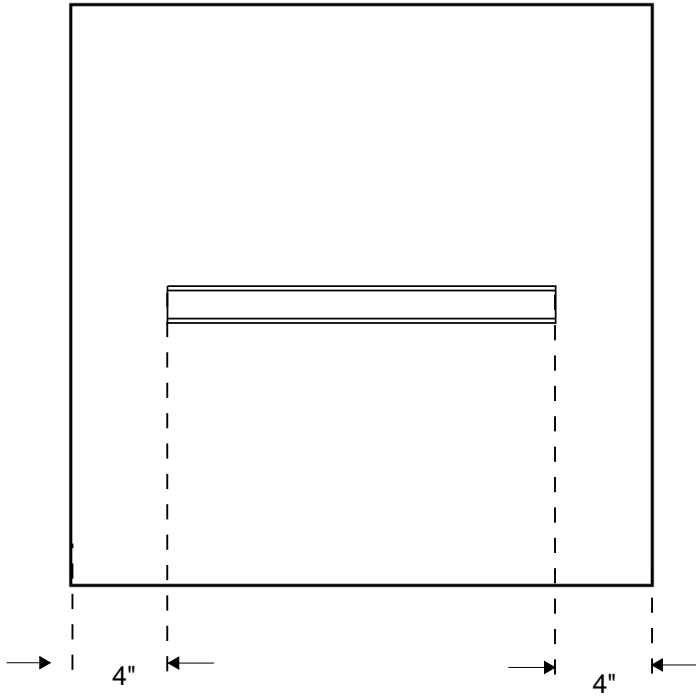

STIFFENER DIMENSIONS DEPENDENT ON PANEL DIMENSIONS. REFERENCE APPROVED SHOP DRAWINGS FOR PANEL DIMENSIONS TO DETERMINE STIFFENER LENGTH.

BOTTOM VIEW

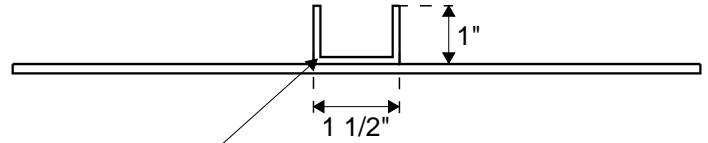

PANEL STIFFENER
ALUMINUM EXTRUSION
X10003

PACKAGE PANEL ASSEMBLIES

PROPERLY PACKAGE AND SECURE PANEL ASSEMBLIES TO ENSURE THEY ARRIVE AT THE JOB SITE INTACT AND READY TO BE INSTALLED.

Fabrication and Installation Instructions

X-Fastenate Panel Framing System: Series 2000

Installation

STEP 1 - CHECK INSTALLATION SITE

TAKE THE NECESSARY STEPS TO ENSURE TRUE-LEVEL AT THE INSTALLATION SITE BEFORE PROCEEDING WITH SECURING THE RAIL TO THE INSTALLATION SURFACE.

TAKING STEPS TO ENSURE TRUE-LEVEL OF THE RAIL TRACKING WILL ENSURE A CLEAN, FLUSH, AND EVEN INSTALLATION OF THE BUNTING PANEL SYSTEM GOING FORWARD.

STEP 2 - INSTALL VERTICAL GULLS ONTO SUPPORT STRUCTURE

BE SURE TO ACCOUNT FOR THE CORRECT NUMBER AND TYPE OF VERTICAL GULLS INSTALLED. REFERENCE APPROVED SHOP DRAWINGS FOR PANELING DESIGN AND SPECIFICATIONS.

CHECK FOR LINE AND LEVEL, AND ENSURE A 1/2" GAP BETWEEN THE ENDS OF RAILS TO ALLOW FOR EXPANSION. FASTEN THE PROFILES IN THE CORRECT LOCATION.

AXONOMETRIC VIEW

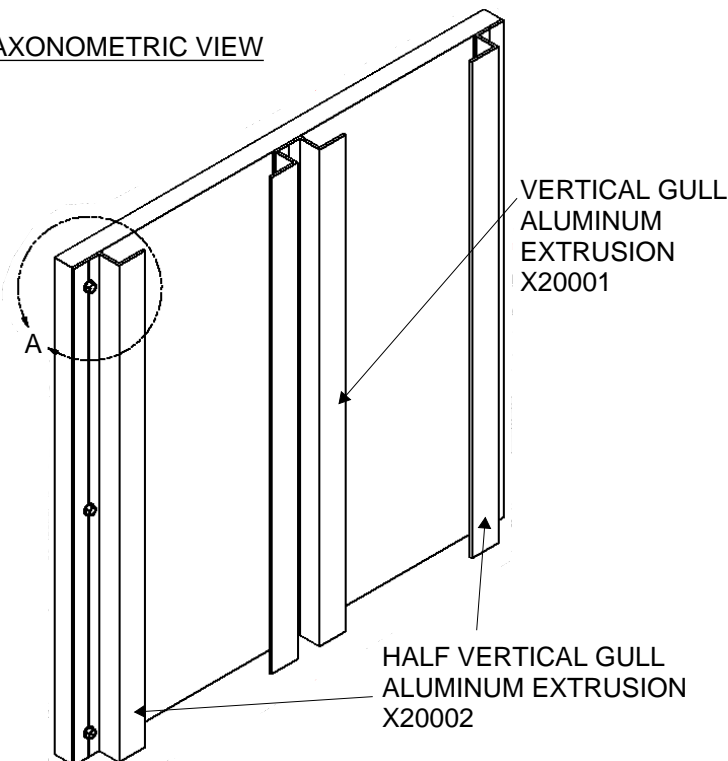

A HALF VERTICAL GULL IS USED FOR WALL PERIMETERS TO ENSURE A CLEAN AND FLUSH FIT ON THE SUPPORT STRUCTURE. HALF GULLS AND INSTALLATION WALL EDGES ARE FLUSH.

DETAIL VIEW - A

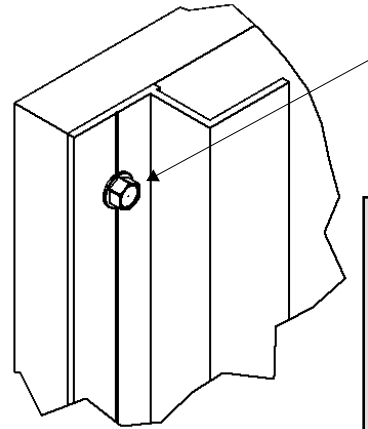

VERTICAL GULL TO RAIL
1/2"-20 x 1 1/2" HWH SS
SELF-DRILLING SCREW
X10004

(12" O.C. TYP.)

SCREW SPACING IS DEPENDENT ON ENGINEERING SPECIFICATIONS AND VERTICAL GULL LENGTH. APPROXIMATELY 12" SPACING IS SHOWN AS A STANDARD.

STEP 3 - CARRY OUT FINAL CHECKS OF ALL GULLS AND PROFILES BEFORE PANELS ARE INSTALLED

CHECKS:

- ON THE PRIMARY ANCHOR TORQUE SETTINGS
- TO THE LINE AND LEVEL OF THE PROFILES IN RELATION TO EACH OTHER
- TO THE NUMBER OF FASTENERS AND THEIR POSITION IN EACH BRACKET
- TO THE PROFILE POSITIONS IN RELATION TO THE ACTUAL PANEL POSITIONS AND JOINTS

STEP 4 - INSTALL THE PANELS ON THE GULLS

REMOVE THE BUNTING ALUMINIUM (TYP.) WALL PANELS FROM THE PROTECTIVE PACKAGING.

FASTEN THE PANELS TO THE VERTICAL GULLS IN PLACE ON THE INSTALLATION WALL.

Fabrication and Installation Instructions

X-Fastenate Panel Framing System: Series 2000

Installation

STEP 4 - INSTALL THE PANELS ON THE GULLS (CONTINUED)

PROCEDURE:

- RAISE THE PANEL AND SUPPORT IN HORIZONTAL POSITION.
- ADJUST LEVEL AND HEIGHT OF PANEL BEFORE FITTING NEXT PANEL ABOVE.
- REPEAT ON NEXT PANELS.
- PANEL JOINTS SHOULD FOLLOW MANUFACTURER'S RECOMMENDATIONS ON HORIZONTAL AND VERTICAL JOINT GAPS.

PROFILES ARE CUT SO THAT PANEL(S) ARE LOCATED ON ONE SET OF VERTICAL PROFILES AND DO NOT BRIDGE AN EXPANSION GAP BETWEEN TWO PROFILES (TYP.).

DIMENSIONS ARE ACCORDING TO A 1/2" NOMINAL VERTICAL REVEAL. REFERENCE APPROVED SHOP DRAWINGS.

FRONT VIEW

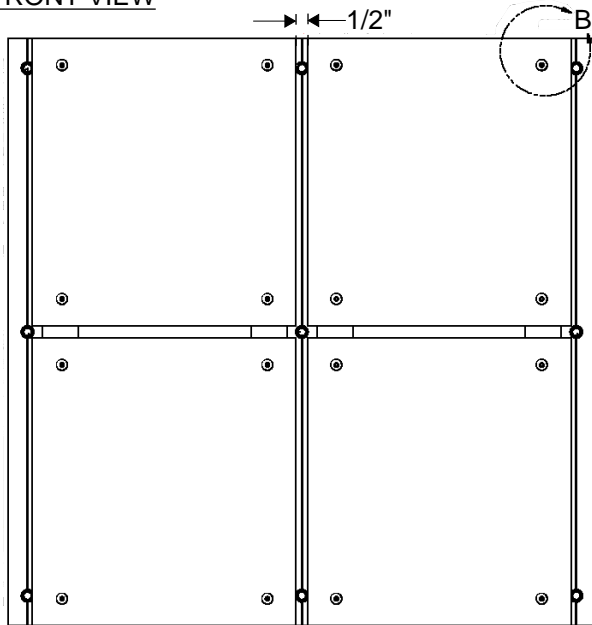

BOTTOM VIEW

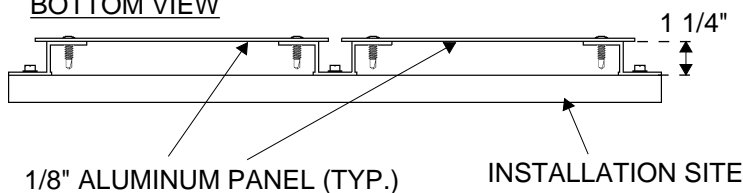

REFERENCE APPROVED SHOP DRAWINGS FOR VERTICAL AND HORIZONTAL DIMENSIONS.

PANEL SHOWN WITHOUT PANEL STIFFENER. IF PANEL DIMENSIONS ARE GREATER THAN 28 SQFT, STIFFENER SHOULD BE IN PLACE.

DETAIL VIEW - B

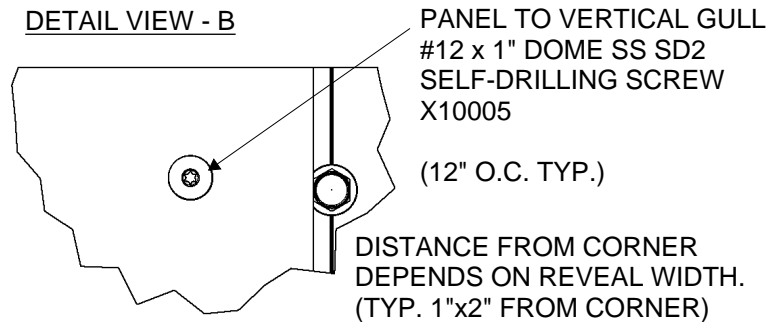

SCREW SPACING IS DEPENDENT ON ENGINEERING SPECIFICATIONS AND PANEL SIZE. 1/2" REVEAL WIDTH IS SHOWN.

INSTALL ALL PANELS ENSURING A FLUSH CONNECTION WITH THE VERTICAL GULLS. INSTALLATION IS COMPLETE WHEN ALL PANELS ARE SECURED IN PLACE ON THE INSTALLATION SITE WALL(S).

NOTES:

FASTENERS:

SUITABLE PRIMARY ANCHORS ARE DESIGNED TO ATTACH THE BRACKETS TO A PRE-DETERMINED GRID TO SUIT THE CLADDING PANEL LAYOUT. STAINLESS STEEL FASTENERS ALSO ASSIST IN PREVENTING BIMETALLIC CORROSION. THE SIZE AND TYPE OF PRIMARY FASTENER FOR THE CONNECTORS WILL ALWAYS BE DETERMINED BY THE DYNAMIC AND DEAD LOADS THAT THEY HAVE TO RESIST.

INSULATION:

WHERE INSULATION IS SPECIFIED, IT SHOULD BE CUT AND TIGHTLY BUTTED AROUND THE GULLS AND SECURED WITH THE APPROPRIATE FASTENERS. SUFFICIENT INSULATION FASTENERS SHOULD BE PROVIDED TO ENSURE THAT THE INSULATION CANNOT BLOCK THE VENTILATED CAVITY.