

# Fabrication and Installation Instructions

## X-Fastenate Panel Framing System: Series 3000

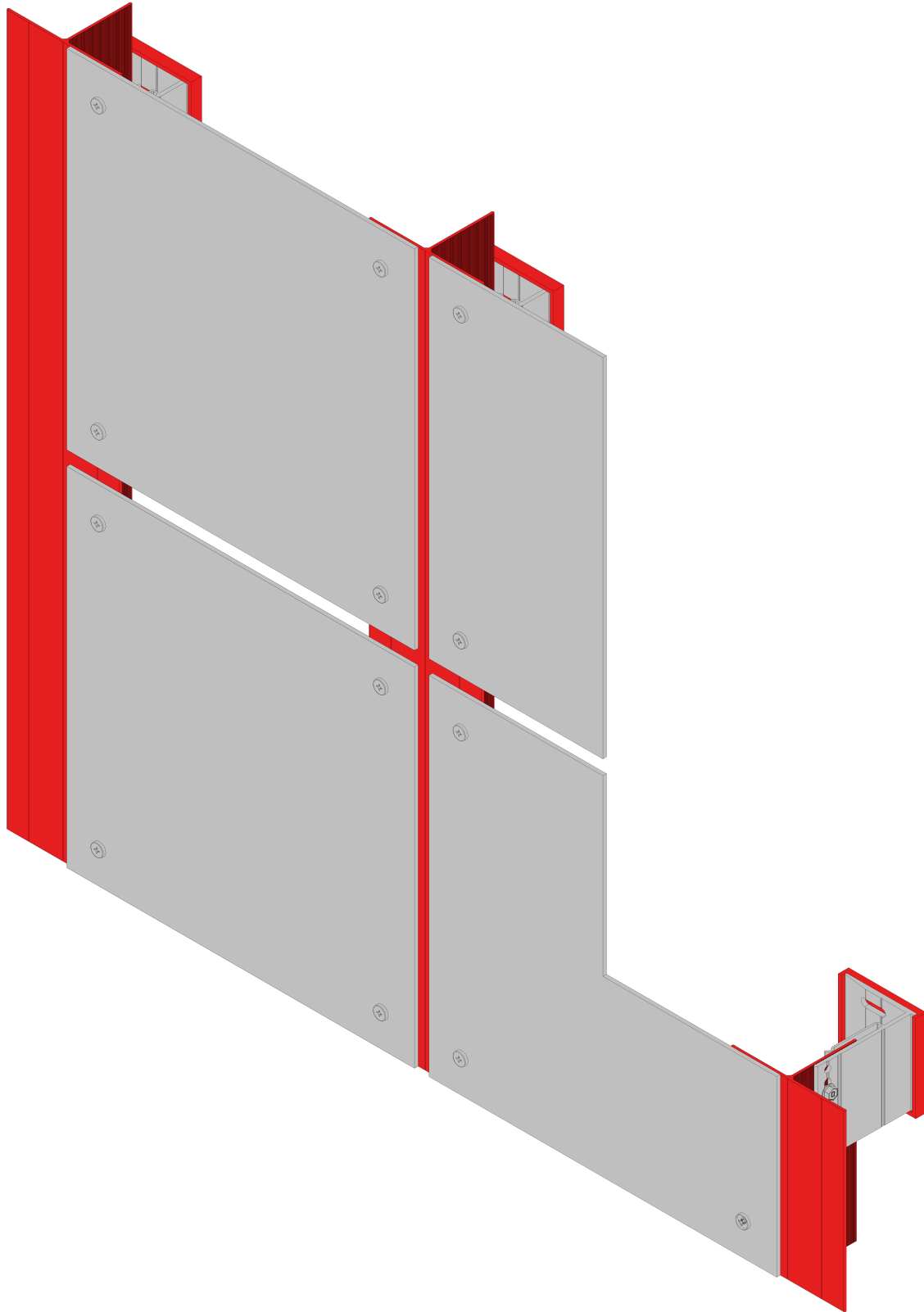

# Fabrication and Installation Instructions

## X-Fastenate Panel Framing System: Series 3000



### Table of Contents

Cover .....	1
Table of Contents .....	2
General Notes/Handling, Storing, and Protecting Aluminum Material .....	3
General Rules .....	4
T-Bracket and Panel Stiffener Fabrication .....	5
Panel and Nvelope Bracket Assembly .....	6
Installation Steps 1 - 3 .....	7
Installation Step 3 .....	8
Installation Steps 4 - 5 .....	9
Installation Step 5 .....	10

# Fabrication and Installation Instructions

## X-Fastenate Panel Framing System: Series 3000

### General Notes

THESE FABRICATION AND INSTALLATION INSTRUCTIONS ARE A SUPPLEMENT TO THE APPROVED SHOP DRAWINGS. USE THIS DOCUMENT IN CONJUNCTION WITH THOSE DRAWINGS.

#### DESIGN PARAMETERS

1. IN ORDER TO ENSURE STRUCTURAL PERFORMANCE, NO OTHER ATTACHMENTS TO THE PANELS OR FRAMING SHOULD BE MADE BY CONTRACTORS OTHER THAN BUNTING, WITHOUT PRIOR WRITTEN APPROVAL FROM BUNTING.

#### STRUCTURE BY OTHERS

1. THE BUILDING STRUCTURE AND COMPONENTS THEREOF MUST BE CAPABLE OF SAFELY CARRYING THE LOADS IMPOSED BY THE PANEL SYSTEM, INCLUDING BUT NOT LIMITED TO DEAD LOADS OF THE PANEL SYSTEM, WIND LOADS SHOWN HEREIN ON DRAWINGS AND/OR CALCULATIONS, THERMAL LOADINGS, SEISMIC LOADINGS, SNOW LOADINGS, AND LIVE LOADINGS.

#### 2. VERIFICATION OF SUBSTRATE:

THE MAXIMUM DEVIATION IN THE PLANE OF THE SUBSTRUCTURE MUST NOT EXCEED +/- 1/4" IN ANY 20 FOOT LENGTH HORIZONTALLY OR VERTICALLY AND CANNOT VARY MORE THAN 1/2" OVER THE ENTIRE BUILDING ELEVATION. TRANSITION AREAS SUCH AS CORNERS AND SOFFITS MUST HAVE THE SUBSTRUCTURE WITHIN +/- 1/8" OF THE THEORETICAL GIRT PLANES. SUBSTRUCTURE ALIGNMENT OUTSIDE OF THE ABOVE LIMITS MUST BE CORRECTED PRIOR TO CLADDING INSTALLATION.

INSTALLATION SHALL NOT PROCEED UNTIL THE SUBSTRUCTURE IS CORRECTED. MAXIMUM SHIM UP TO 1/4" AS REQUIRED TO BRING THE GIRT PLANE TO WITHIN +/- 1/16" OF THE THEORETICAL GIRT PLANE. SHIMMING MAY REQUIRE LONGER FASTENERS.

THE SURFACE OF THE GIRT TO WHICH PANELS ARE TO BE ATTACHED MUST BE FREE OF BOLT AND RIVET HEADS, EXCESSIVE WELDS, OR ANY OTHER OBSTRUCTIONS WHICH COULD PREVENT PROPER BEARING. ALL STRUCTURAL SUPPORTS SHALL BE IN PLACE AND ALL SAG RODS, DIAGONAL BRACING, AND CONNECTIONS SHALL BE TIGHTENED BEFORE WORK PROCEEDS. WELD ALL SLOTTED CONNECTIONS INTENDED FOR ALIGNMENT PURPOSES ONLY UPON COMPLETION OF ALIGNMENT.

IN NO CASE SHALL GIRTS BE ERECTED AND ALIGNED PRIOR TO POURING THE FLOOR AND/OR ROOF SLABS. DEAD LOAD DEFLECTIONS WILL CAUSE SEVERE GIRT ALIGNMENT PROBLEMS.

3. CONCRETE MUST BE 6000 PSI OR BETTER TO MOUNT THE PANEL SYSTEM.

EVERY EFFORT IS BEING MADE TO ELIMINATE ERRORS; HOWEVER, SINCE ERRORS CAN AND WILL HAPPEN, BUNTING WILL NOT ASSUME RESPONSIBILITY BEYOND MANUFACTURING IN ACCORDANCE WITH APPROVED DRAWINGS OR RESPONSIBILITY FOR ERRORS RESULTING FROM THE USE OF THESE DRAWINGS BY OTHER TRADES.

### Handling, Storing, and Protecting Aluminum Material

THE FOLLOWING PRECAUTIONS ARE RECOMMENDED TO ASSURE EARLY ACCEPTANCE OF YOUR PRODUCTS AND WORKMANSHIP.

A) HANDLE CAREFULLY - DO NOT DROP FROM THE TRUCK. STACK WITH ADEQUATE SEPARATION SO MATERIAL WILL NOT RUB TOGETHER. STORE OFF THE GROUND. PROTECT AGAINST ELEMENTS AND OTHER CONSTRUCTION TRADES.

B) KEEP MATERIAL AWAY FROM WATER, MUD, AND SPRAY - PREVENT CEMENT, PLASTER, AND OTHER MATERIALS FROM DAMAGING THE FINISH.

C) PROTECT THE MATERIALS AFTER ERECTION BY WRAPPING WITH KRAFT PAPER - OR BY ERECTING VISQUEEN/CANVAS SPLATTER SCREENS. CEMENT, PLASTER, TERRAZZO, AND OTHER ALKALINE MATERIALS ARE VERY HARMFUL TO THE FINISH AND SHOULD BE REMOVED WITH WATER AND MILD SOAP BEFORE SETTING OCCURS. UNDER NO CIRCUMSTANCES ALLOW THESE MATERIALS TO DRY OR PERMANENT STAINING WILL OCCUR. PRIOR TO THE SETTING OF OTHER MATERIALS REQUIRE THE CONTRACTOR TO CLOSELY SUPERVISE OTHER TRADES SO AS TO PREVENT MARRING OR DISCOLORATION FROM ANY CAUSE.

D) GENERAL CONTRACTOR SHALL TAKE NECESSARY MEASURE TO PROTECT ALUMINUM FROM WELDING OPERATIONS BY CONTRACTORS OTHER THAN BUNTING.

# Fabrication and Installation Instructions

## X-Fastenate Panel Framing System: Series 3000

### General Rules

THE FOLLOWING PRACTICES ARE RECOMMENDED FOR ALL INSTALLATIONS.

A) READ COMPLETE INSTRUCTIONS BEFORE ORDERING PANELS OR FABRICATED MATERIAL.

B) CHECK SHOP DRAWINGS TO BECOME THOROUGHLY FAMILIAR WITH THE JOB.

C) ALL MATERIALS ARE TO BE INSTALLED PLUMB, LEVEL, AND TRUE.

D) ALL WORK SHOULD START FROM ESTABLISHED BENCH MARKS AND COLUMN CENTER LINES ESTABLISHED BY THE ARCHITECTURAL DRAWINGS AND THE GENERAL CONTRACTOR.

E) THE SEQUENCE OF ERECTION SHOULD BE COORDINATED WITH THE JOB SUPERINTENDENT SO DELAYS ARE PREVENTED AND RISK OF MATERIAL DAMAGE IS MINIMIZED. IF PRESETTING OF ANCHORAGE IS REQUIRED, COORDINATE WITH GENERAL CONTRACTOR AND SUPERVISE LOCATION.

F) MAKE CERTAIN CONSTRUCTION WHICH WILL RECEIVE YOUR MATERIALS IS ACCORDING TO THE CONTRACT DOCUMENTS. IF NOT, NOTIFY THE GENERAL CONTRACTOR IN WRITING AND RESOLVE DIFFERENCES BEFORE PROCEEDING WITH YOUR WORK.

G) INSULATE ALL ALUMINUM TO BE PLACED DIRECTLY IN CONTACT WITH THE MASONRY OR INCOMPATIBLE MATERIALS WITH A HEAVY COAT OF ZINC CHROMATE OR BITUMINOUS PAINT. ALL MILL FINISHED/UNFINISHED ALUMINUM MUST HAVE A SEPARATOR (NON-METALLIC) BETWEEN DISSIMILAR METALS.

H) FOLLOW BUNTING FABRICATION AND INSTALLATION INSTRUCTIONS.

I) CHECK ALL MATERIAL ON ARRIVAL FOR QUANTITY.

J) BE SURE TO HAVE ALL THE MATERIALS AND TOOLS NEEDED TO BEGIN THE INSTALLATION.

1. APPROVED SHOP DRAWINGS.
2. LEVEL AND PLUMB (TRANSIT).
3. FASTENERS AND REQUIRED DRILL BITS AND DRIVERS.
4. PERIMETERS AND ACCESSORIES SUCH AS ANCHORS, FASTENERS, AND END CAPS.
5. METAL PANELS FOLLOWING THE DESIGN SPECIFICATIONS.

# Fabrication and Installation Instructions

## X-Fastenate Panel Framing System: Series 3000

### T-Bracket Fabrication

REFERENCE APPROVED SHOP DRAWINGS FOR VERTICAL LENGTHS. ACTUAL PROJECT CONDITIONS WILL DETERMINE SPECIFIC T-BRACKET DESIGN AND QUANTITY.

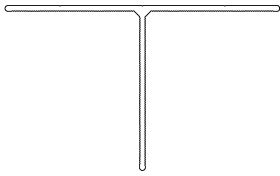

T-BRACKET  
X30001  
USED FOR MIDDLE  
PANEL CONNECTIONS

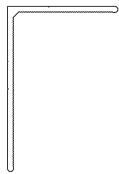

L-BRACKET  
X30002  
USED FOR PERIMETER  
PANEL CONNECTIONS  
(PARAPETS, OPENING  
SILLS, ETC.)

T-BRACKET AND L-BRACKET HAVE THE SAME FABRICATION METHOD. T-BRACKET IS SHOWN. FOLLOW THESE STEPS AND DIMENSIONS FOR L-BRACKET FABRICATION.

BE SURE TO ACCOUNT FOR CORRECT NUMBER OF EACH TYPE OF BRACKET.

CUT THE VERTICAL T-BRACKET EXTRUSION TO THE INSTALLATION WALL HEIGHT.

#### AXONOMETRIC VIEW

T-BRACKET LENGTH IS DEPENDENT ON PANEL AND INSTALLATION SITE DIMENSIONS.

MOUNTING HOLES MAY BE FIELD DRILLED IF DEEMED NECESSARY. REFERENCE APPROVED SHOP DRAWINGS.

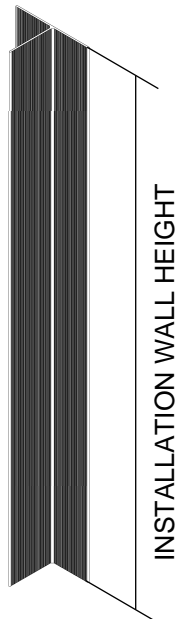

### Panel Stiffener Fabrication

THE FOLLOWING STEPS SHOULD ONLY BE TAKEN IF THE PANEL SIZE IS GREATER THAN 28 SQUARE FEET.

CUT THE 1 1/2" x 1" CHANNEL STIFFENER TO 8" SHORTER THAN THE PANEL WIDTH. SPACING OF STIFFENER(S) DETERMINED BY ENGINEERING CALCULATIONS.

STIFFENER WILL LAY FLAT DIRECTLY AGAINST THE ALUMINUM PANEL.

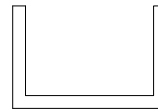

PANEL STIFFENER  
ALUMINUM EXTRUSION  
X10003

#### BACK VIEW

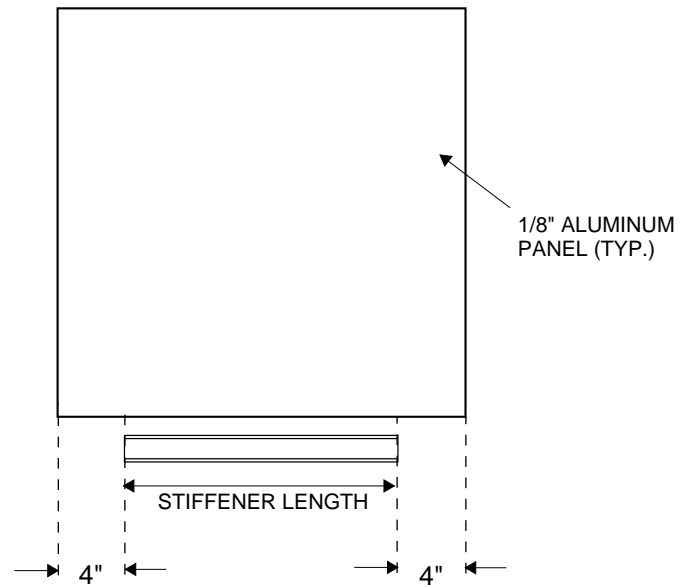

STIFFENER DIMENSIONS DEPENDENT ON PANEL DIMENSIONS. REFERENCE APPROVED SHOP DRAWINGS FOR PANEL DIMENSIONS TO DETERMINE STIFFENER LENGTH.

# Fabrication and Installation Instructions

## X-Fastenate Panel Framing System: Series 3000

### Panel Assembly

THE FOLLOWING STEPS SHOULD ONLY BE TAKEN IF THE PANEL SIZE IS GREATER THAN 28 SQUARE FEET.

APPLY VHB TAPE TO THE BASE OF THE STIFFENER AND SECURE IT TO THE PANEL ASSEMBLY TO SUPPORT THE CENTER OF THE PANEL.

CENTER THE STIFFENER HORIZONTALLY, CREATING A 4" GAP BETWEEN THE STIFFENER AND PANEL ON BOTH ENDS TO ALLOW FOR EXPANDING AND CONTRACTING UNDER DIFFERENT WEATHER CONDITIONS.

#### BACK VIEW

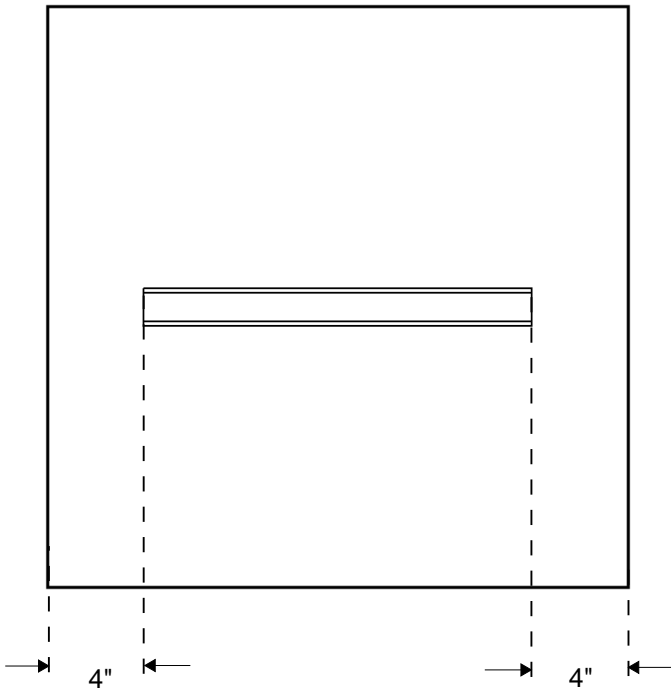

STIFFENER DIMENSIONS DEPENDENT ON PANEL DIMENSIONS. REFERENCE APPROVED SHOP DRAWINGS FOR PANEL DIMENSIONS TO DETERMINE STIFFENER LENGTH.

#### BOTTOM VIEW

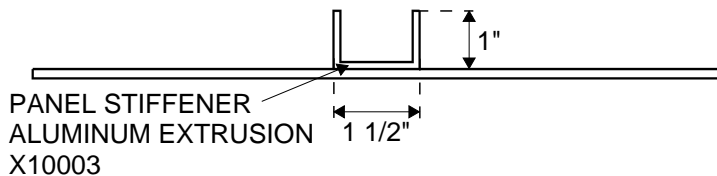

### Nvelope Bracket Assembly

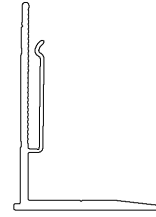

NVELOPE BRACKET (PRE-ORDERED PART)

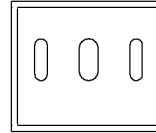

NVELOPE ISOLATOR (PRE-ORDERED PART)

PRE-FIX THE NVELOPE BRACKET AND THE NVELOPE ISOLATOR IN ORDER TO ENABLE EFFICIENT INSTALLATION AT THE JOB SITE.

#### AXONOMETRIC VIEW

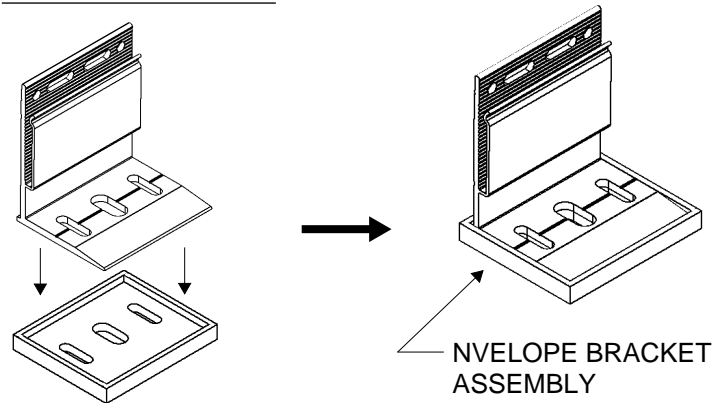

BE SURE TO ACCOUNT FOR THE CORRECT NUMBER AND SIZE OF BRACKETS TO BE INSTALLED. REFERENCE APPROVED SHOP DRAWINGS.

#### PACKAGE PANEL ASSEMBLIES AND BRACKET ASSEMBLIES

PROPERLY PACKAGE AND SECURE PANEL ASSEMBLIES AND BRACKET ASSEMBLIES TO ENSURE THEY ARRIVE AT THE JOB SITE INTACT AND READY TO BE INSTALLED.

# Fabrication and Installation Instructions

## X-Fastenate Panel Framing System: Series 3000

### Installation

#### STEP 1 - CHECK INSTALLATION SITE

TAKE THE NECESSARY STEPS TO ENSURE TRUE-LEVEL AT THE INSTALLATION SITE BEFORE PROCEEDING WITH SECURING THE RAIL TO THE INSTALLATION SURFACE.

TAKING STEPS TO ENSURE TRUE-LEVEL OF THE RAIL TRACKING WILL ENSURE A CLEAN, FLUSH, AND EVEN INSTALLATION OF THE BUNTING PANEL SYSTEM GOING FORWARD.

#### STEP 2 - INSTALL NVELOPE BRACKET ASSEMBLIES ONTO SUPPORT STRUCTURE

BRACKET HEIGHT AND SPACING PER PROJECT SPECIFIC ENGINEERING. REFERENCE APPROVED SHOP DRAWINGS.

#### AXONOMETRIC VIEW

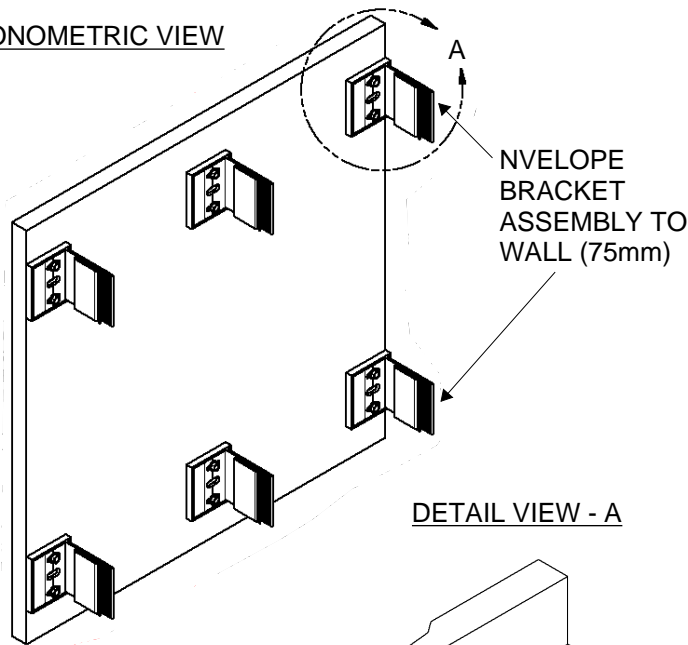

#### DETAIL VIEW - A

NVELOPE BRACKET TO RAIL  
1/2"-20 x 1 1/2" HWH SS SD2  
SELF-DRILLING SCREW  
X10006

90mm DEPTH BRACKET IS SHOWN.  
DETAILS FOR OTHER BRACKETS ARE SIMILAR.

REFERENCE DETAILING MANUAL FOR OTHER DIMENSION OPTIONS.

#### TOP VIEW

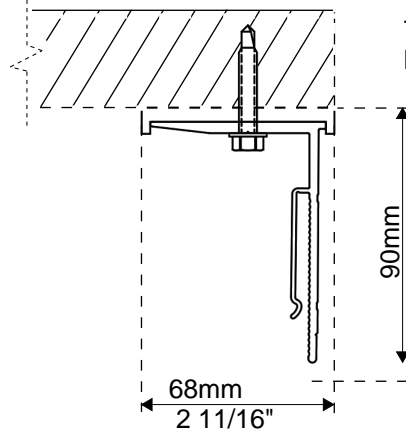

TOP DIMENSIONS ARE THE SAME FOR THE 75mm AND 150mm NVELOPE BRACKETS.

ALL BRACKETS FEATURE +/- 5/8" ADJUSTABILITY TO ACCOUNT FOR IMPERFECTIONS IN THE MOUNTING SUBSTRATE.

#### STEP 3 - INSTALL THE T-BRACKETS OR L-BRACKETS IN CONNECTION TO THE NVELOPE BRACKETS

CAVITY LENGTH IS DETERMINED PER PROJECT SPECIFIC ENGINEERING. REFERENCE APPROVED SHOP DRAWINGS FOR CAVITY DIMENSIONS AND T-BRACKET/L-BRACKET PLACEMENT.

PUSH THE T-BRACKET/L-BRACKET INTO THE NVELOPE BRACKET HELPING HAND AND ADJUST FOR LINE AND LEVEL.

#### TOP VIEW

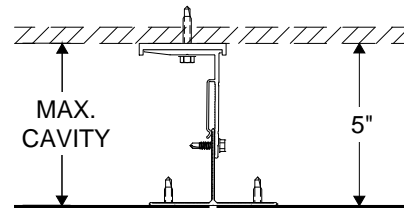
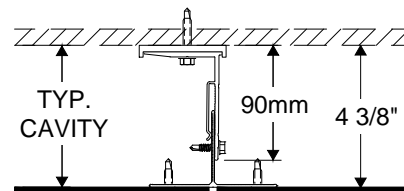
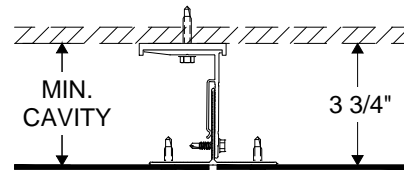

REFERENCE DETAILING MANUAL FOR OTHER DIMENSION OPTIONS.

# Fabrication and Installation Instructions

## X-Fastenate Panel Framing System: Series 3000

### Installation

#### STEP 3 - INSTALL THE T-BRACKETS OR L-BRACKETS IN CONNECTION TO THE NVELOPE BRACKETS (CONTINUED)

CHECK FOR LINE AND LEVEL, AND ENSURE A 1/2" GAP BETWEEN THE ENDS OF RAILS TO ALLOW FOR EXPANSION. FASTEN THE PROFILES IN THE CORRECT LOCATION.

90mm BRACKET IS SHOWN.

#### SIDE VIEW

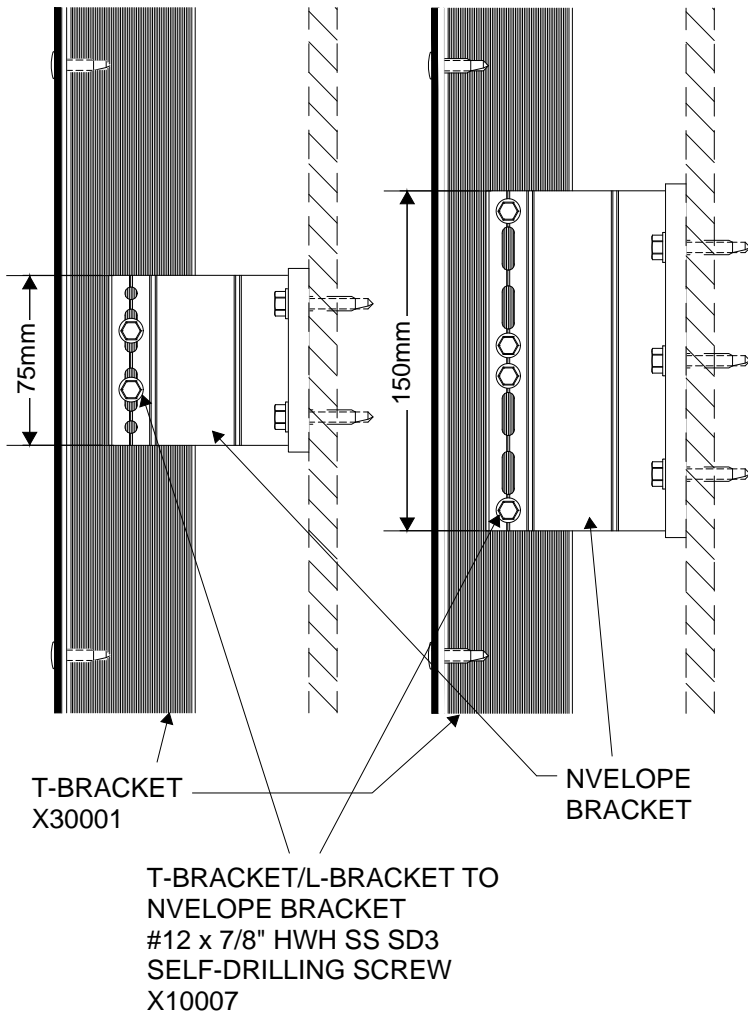

BRACKET HEIGHT SELECTION AND SPACING PER PROJECT SPECIFIC ENGINEERING.

FOR T-BRACKET/L-BRACKET TO NVELOPE BRACKET CONNECTIONS:

EACH RAIL SHOULD HAVE A FIXED CONNECTION TO ONLY ONE BRACKET AND THE REMAINING BRACKETS SHOULD HAVE SLOTTED CONNECTIONS.

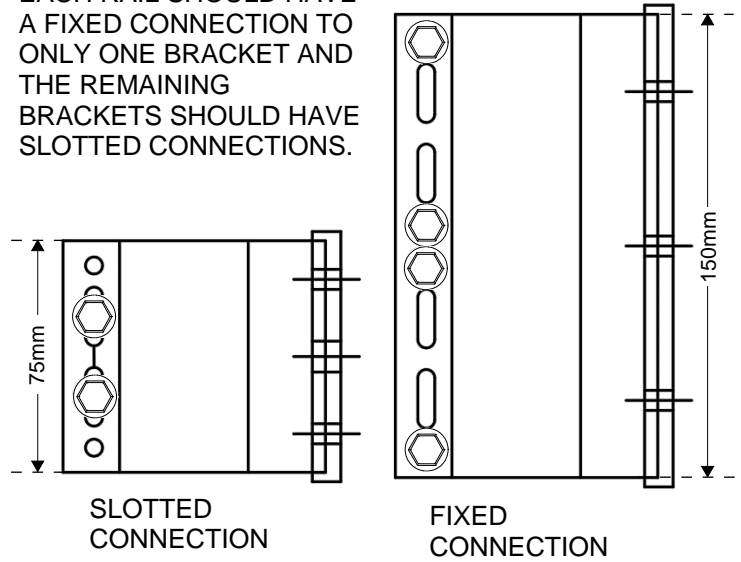

INSTALLATION IN THIS MANNER FOLLOWS THE BEST INSTALLATION PRACTICE BUT IS NOT A REPLACEMENT FOR PROJECT SPECIFIC ENGINEERING. SHOP DRAWINGS TAKE PRECEDENCE.

#### AXONOMETRIC VIEW

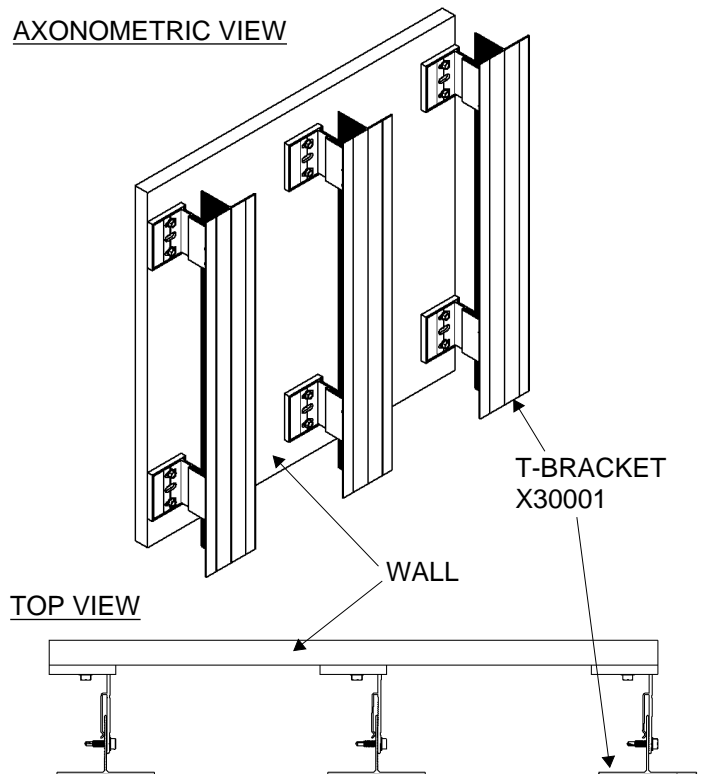

# Fabrication and Installation Instructions

## X-Fastenate Panel Framing System: Series 3000

### Installation

#### STEP 4 - CARRY OUT FINAL CHECKS OF ALL BRACKETS AND PROFILES BEFORE PANELS ARE INSTALLED

##### CHECKS:

- ON THE PRIMARY ANCHOR TORQUE SETTINGS
- TO THE LINE AND LEVEL OF THE PROFILES IN RELATION TO EACH OTHER
- TO THE NUMBER OF FASTENERS AND THEIR POSITION IN EACH BRACKET
- TO THE PROFILE POSITIONS IN RELATION TO THE ACTUAL PANEL POSITIONS AND JOINTS

#### STEP 5 - INSTALL THE PANELS ONTO THE T-BRACKETS AND L-BRACKETS

REMOVE THE BUNTING ALUMINIUM (TYP.) WALL PANELS FROM THE PROTECTIVE PACKAGING.

FASTEN THE PANELS TO THE FLAT PART OF THE T-BRACKETS AND L-BRACKETS IN PLACE ON THE INSTALLATION WALL.

##### PROCEDURE:

- RAISE THE PANEL AND SUPPORT IN HORIZONTAL POSITION.
- ADJUST LEVEL AND HEIGHT OF PANEL BEFORE FITTING NEXT PANEL ABOVE.
- REPEAT ON NEXT PANELS.
- PANEL JOINTS SHOULD FOLLOW MANUFACTURER'S RECOMMENDATIONS ON HORIZONTAL AND VERTICAL JOINT GAPS.

PROFILES ARE CUT SO THAT PANEL(S) ARE LOCATED ON ONE SET OF VERTICAL PROFILES AND DO NOT BRIDGE AN EXPANSION GAP BETWEEN TWO PROFILES (TYP.).

DIMENSIONS ARE BASED ON A 1/2" NOMINAL REVEAL WIDTH. REFERENCE APPROVED SHOP DRAWINGS.

##### TOP VIEW

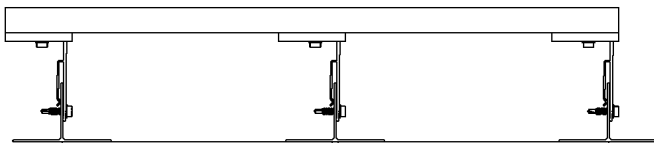

##### FRONT VIEW

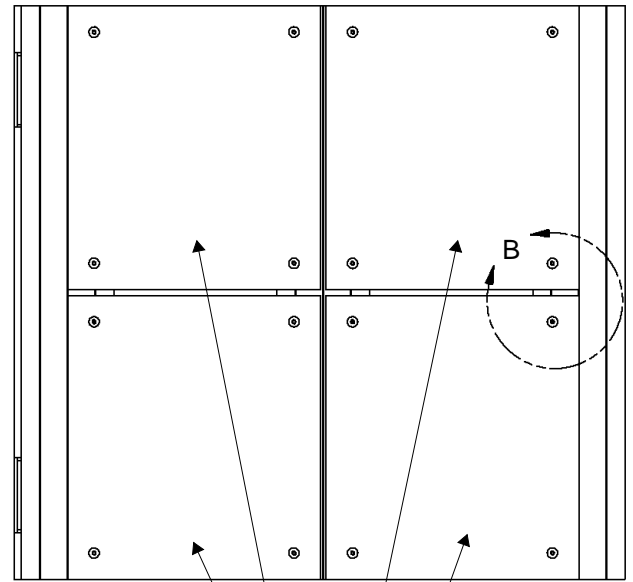

1/8" ALUMINIUM PANEL (TYP.)

PANEL SHOWN WITHOUT PANEL STIFFENER. IF PANEL DIMENSIONS ARE GREATER THAN 28 SQFT, STIFFENER SHOULD BE IN PLACE.

##### DETAIL VIEW - B

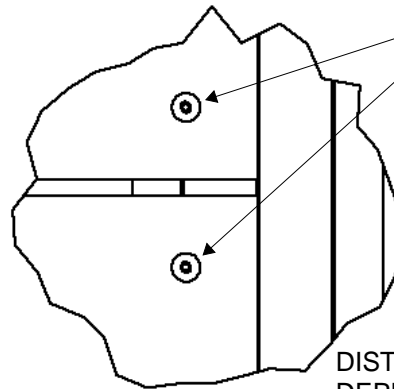

PANEL TO T-BRACKET/L-BRACKET #12 x 1" DOME SS SD2 SELF-DRILLING SCREW X10005

(12" O.C. TYP.)

DISTANCE FROM CORNER DEPENDS ON REVEAL WIDTH. (TYP. 1"x2" FROM CORNER)

SCREW SPACING IS DEPENDENT ON ENGINEERING SPECIFICATIONS AND PANEL SIZE. 1/2" REVEAL WIDTH IS SHOWN.

# Fabrication and Installation Instructions

## X-Fastenate Panel Framing System: Series 3000

### Installation

#### STEP 5 - INSTALL THE PANELS ONTO THE T-BRACKETS AND L-BRACKETS (CONTINUED)

INSTALL ALL PANELS ENSURING A FLUSH CONNECTION WITH THE T-BRACKETS AND L-BRACKETS. INSTALLATION IS COMPLETE WHEN ALL PANELS ARE SECURED IN PLACE ON THE INSTALLATION SITE WALL(S).

REFERENCE APPROVED SHOP DRAWINGS FOR VERTICAL AND HORIZONTAL DIMENSIONS.

#### AXONOMETRIC VIEW

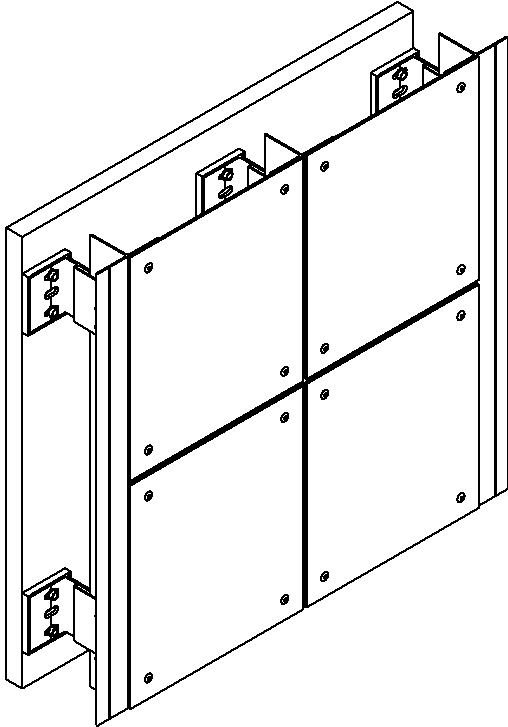

#### NOTES:

##### FASTENERS:

SUITABLE PRIMARY ANCHORS ARE DESIGNED TO ATTACH THE BRACKETS TO A PRE-DETERMINED GRID TO SUIT THE CLADDING PANEL LAYOUT. STAINLESS STEEL FASTENERS ALSO ASSIST IN PREVENTING BIMETALLIC CORROSION. THE SIZE AND TYPE OF PRIMARY FASTENER FOR THE CONNECTORS WILL ALWAYS BE DETERMINED BY THE DYNAMIC AND DEAD LOADS THAT THEY HAVE TO RESIST.

##### INSULATION:

INSTALL THE INSULATION PRIOR TO THE PANELS. WHERE INSULATION IS SPECIFIED, IT SHOULD BE CUT AND TIGHTLY BUTTED AROUND THE BRACKETS AND SECURED WITH THE APPROPRIATE FASTENERS. SUFFICIENT INSULATION FASTENERS SHOULD BE PROVIDED TO ENSURE THAT THE INSULATION CANNOT BLOCK THE VENTILATED CAVITY.